

NT818
GPS Engine Board Module
Specification



Version 1.3

2007/4/30

1. Product Information

■ Product Name: NT818

■ Product Description:

NT818 engine board is a super compact size GPS (Global Positioning System) module By using SiRF Star III (GSC3f/LP Base band processor with integrated Flash memory, and RF front end) high performance and lower power consumption chipset technology, NT818 GPS module processes high sensitivity to satellite signals with low power consumption. It is best-suited to be integrated into various portable electronic devices for use in automotive, handheld navigation, cellular handset, mobile computing and other GPS applications.



■ Product Features:

- ::: Build on high performance, low-power SiRF star III chipset
- ::: Extreme fast TTF (the time to first fix) at low signal level
- ::: 20 –channel GPS receiver
- ::: SBAS (WAAS, EGNOS Euro Geostationary Navigation Overlay Service) support
- ::: Full navigation accuracy provided by Standard Positioning Service (SPS)
- ::: Reception frequency 1575.42MHz
- ::: CPU (ARM7TDMI) with 4Mb of internally packaged Flash memory
- ::: Advanced Power Management. (The mode of low power management when signal levels are less than 30dB Hz. Update rates are limited from 10 seconds to 255 seconds.)
- ::: 2 UARTS, high speed serial bus
- ::: Support standard NMEA 0183 protocol (Version. 3.0 GGA, GSA, GSV, RMC, VTG)
- ::: Internal RTC (Real Time Clock)
- ::: Compact Engine Board Size 15x13x2.2mm (WxLxH) without patch antenna
- ::: Shielding case included

2. Technical Information

■ Characteristics

::: Acquisition time (Open Sky and Stationary)

Reacquisition		Average 0.1 seconds
Hot start	<	Average 1 seconds
Warm start	<	Average 38 seconds
Cold start	<	Average 42 seconds

::: Accuracy

Position		10 meters RMS without SA
Velocity		0.1 meters/second, without SA
Time		1 microsecond synchronized to GPS time
Datum		WGS-84 (or by demand)

::: Sensitivity

Tracking sensitivity		-159dBm
----------------------	--	---------

::: Dynamics

Altitude	<	18000 meter maximum
Velocity	<	515 meter/second maximum
Acceleration	<	4g

::: Frequency

		L1, 1575.42 MHz C/A code
--	--	--------------------------

■ Power

::: Power consumption

		under 75mA fully active
--	--	-------------------------

::: Power Management

Advanced Power Management. (The mode of low power management when signal levels are less than 30dB Hz. Update rates are limited from 10 seconds to 255 seconds.)

■ Interface

- ∴ Baud rate Default baud rate for NMEA is 4800, N, 8, 1.
Default baud rate for SiRF binary mode is 57600, N, 8, 1.
- ∴ Serial I/O port High speed UART-TTL signal.
- ∴ I/O Protocol NMEA 0183 V3.0 (default)
- ∴ I/O Connector 22 pin SMD type
- ∴ RF Connector SMD PAD for Patch Antenna

■ Physical Characteristics

- ∴ Dimensions 15 x 13 x 2.2 mm [W x L x H] w/o patch antenna
- ∴ Weight 3.5g
- ∴ Vibration 4G Max.

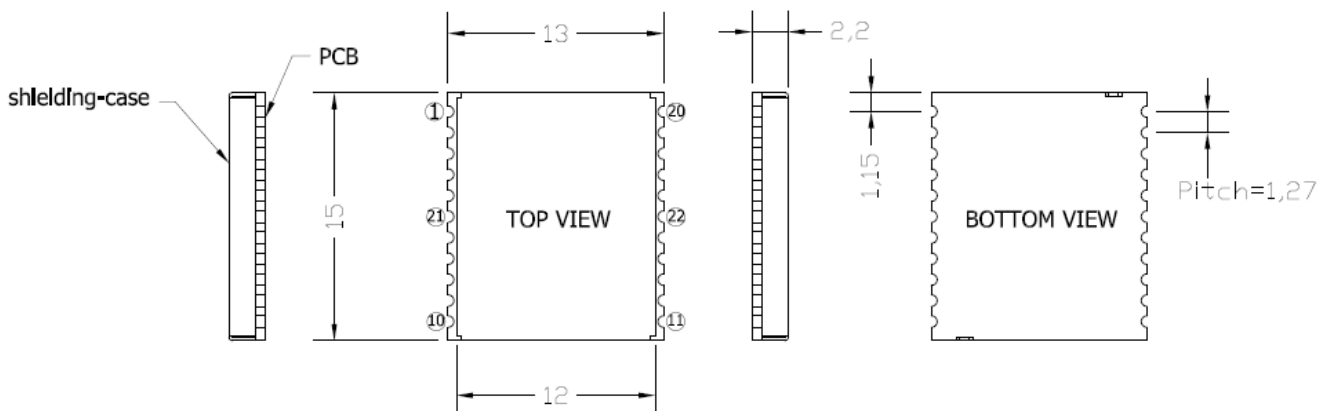

■ Environment Conditions

- ∴ Operating Temperature -20°C to +80°C
- ∴ Storage Temperature -20°C to +85°C
- ∴ Operating Humidity 5% ~ 95% RH, Non condensing

■ Functional Block Diagram

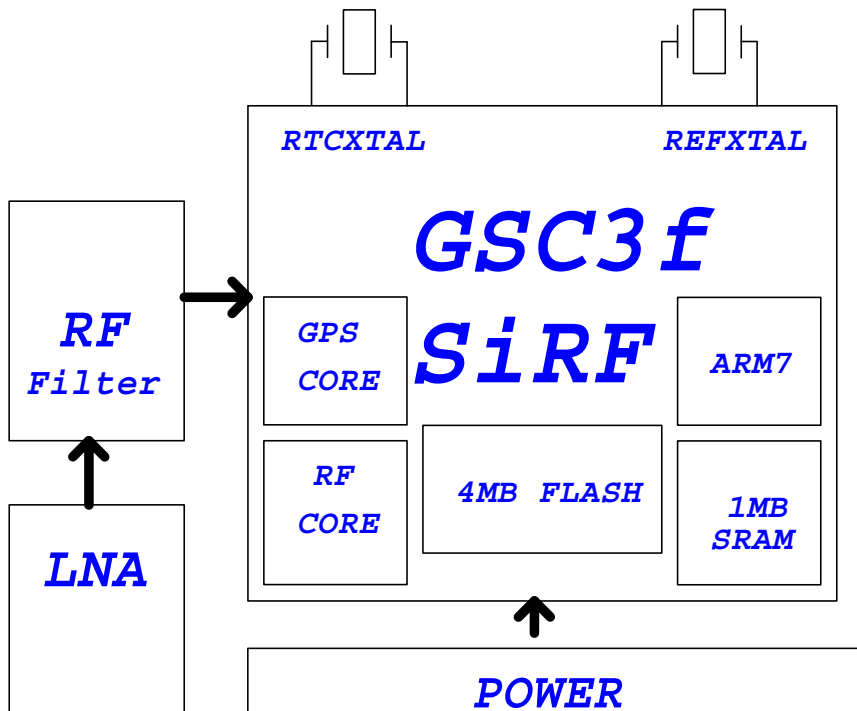

■ Pin Assignment of connector

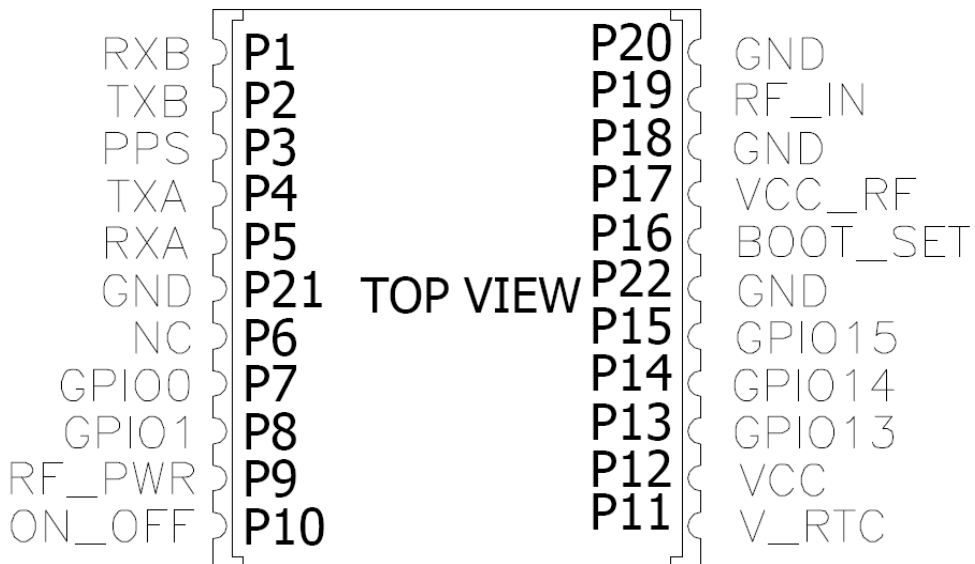

■ Recommended land pattern dimension

Model : EB818

Recommended land pattern dimensions

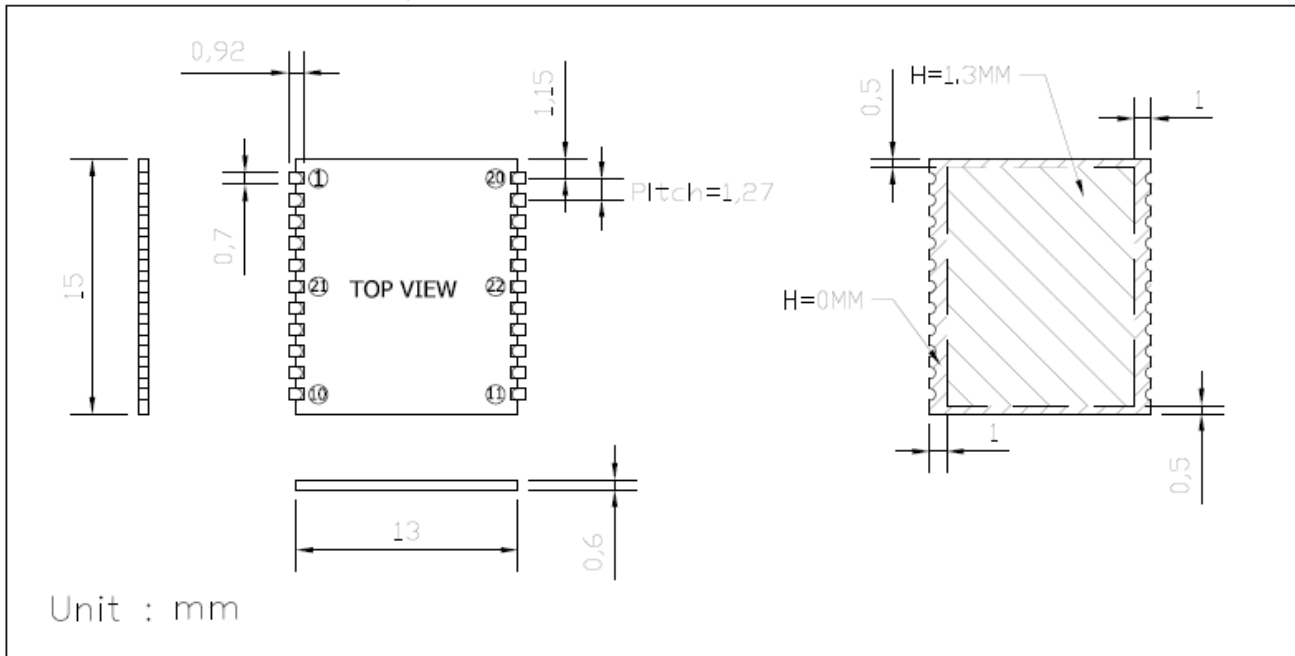

■ Application Circuit

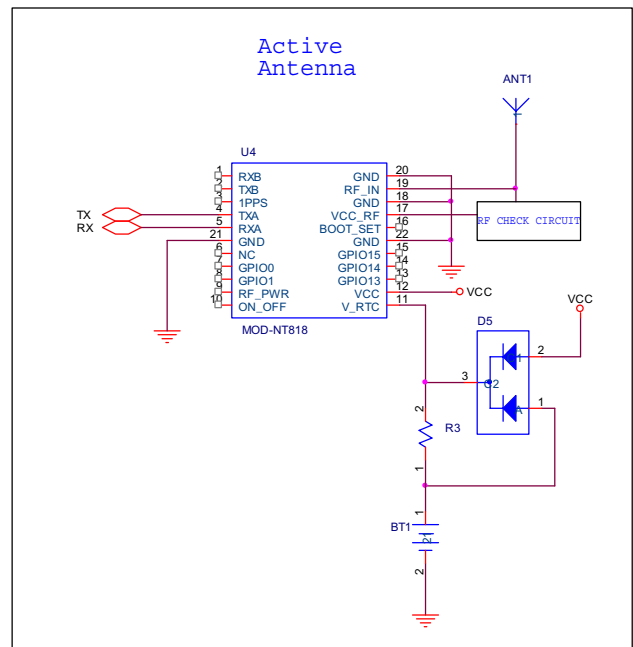
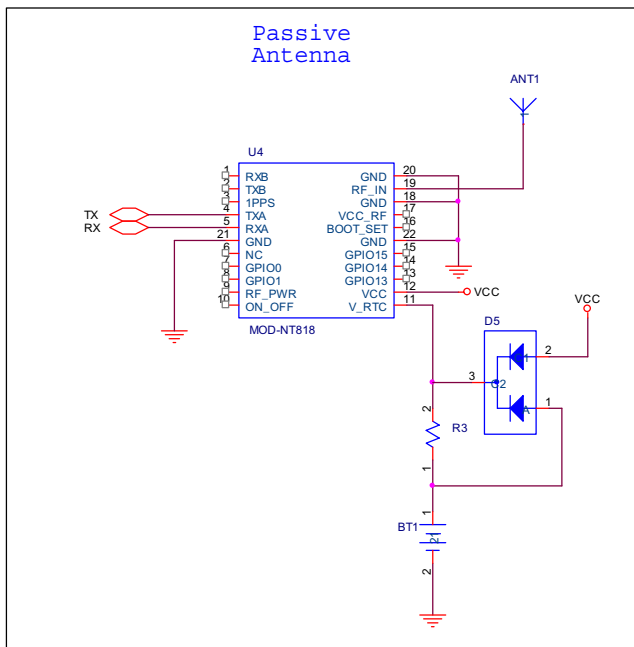

■ Pin assignment description

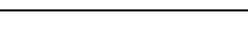
NT818 Pin assignment description		
Pin 1	RXB	Serial Data input port B for user's application (not currently used).
2	TXB	Serial Data output port B for user's application (not currently used).
3	PPS	1PPS Time mark output
4	TXA	Serial Data output port A
5	RXA	Serial Data input port A
6	NC	
7	GPIO0	General purpose I/O
8	GPIO1	General purpose I/O
9	RF_PWR	RF_PWR ON/OFF
10	ON_OFF	Edge triggered soft on/off request. Should only be used to wake up chip.(must be Low)
11	V_RTC	Battery backup input. 2.8V to 3.3V ,10uA typical.
12	VCC	3V +/- 0.15V power input (System Power)
13	GPIO13	General purpose I/O
14	GPIO14	General purpose I/O
15	GPIO15	LED indicate for GPS status
<p>Tracking Mode : </p> <p>Fixed Mode : Hi </p>		
16	BOOT_SET	Reserved for re-programming flash(pull high)
17	VCC_RF	RF POWER 2.85V
18	GND	Power GND
19	RF_IN	Antenna input
20	GND	Power GND
21	GND	Power GND
22	GND	Power GND